

Description: RX-BKT50-500250 RGBW Flexible Module LED Sheet Large size LED strip, Patent: ZL201420249938.2, Flexible LED modules; you can cut and splice, making any shape LED module, RGBW Four channels, Dimming and color adjustment. Ideal for Light source, Backlighting for advertising, Blister words backlit, LED signs Do your own. energy-saving lighting project.

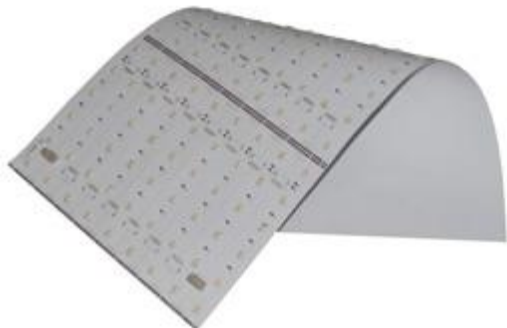

1. RGBW Four channels, Dimming and color adjustment.
2. Slim light box LED sheet module, depth 50mm
3. High quality LED chip, High luminous efficiency, high reliability
4. Size 500x250mm, LED spacing 28mm, LED QTY 162pcs
5. Patent: ZL201420249938.2
6. CV input DC24V, Easy to expand installation
7. Warranty 2 years
8. CE RoHS FCC PSE

Model	Dimension Net weight	Luminous Flux	Efficacy Typ	Power Test	Rated Power IN DC24V	Comment
RX-BKT50-500250	500x250x2mm 100g	Red 332Lm	27Lm/W	12.2W	12.5W/CH 50W/4CH	T _{cp} 46°C Continuous connection 4pcs Double cable
		Green 851Lm	70Lm/W	12.1W		
		Blue 194Lm	16Lm/W	12W		
		WWhite 1188Lm	86Lm/W	13.8W		

The above table data testing at room temperature is 25 °C, Cooling by free air convection, Surface temperature rise T_c 28 K
 Operation Temperature: -30 °C ~ 70°C At the T_c point, Lifetime: 40,000 hrs (Note: T_{cp} < 60 °C)
 Tolerance range for optical and electrical data: ±10 %
 Constant voltage RGBW controller must be used. Please note the output current of the RGBW controller, More than the LED module current!

Dimension:

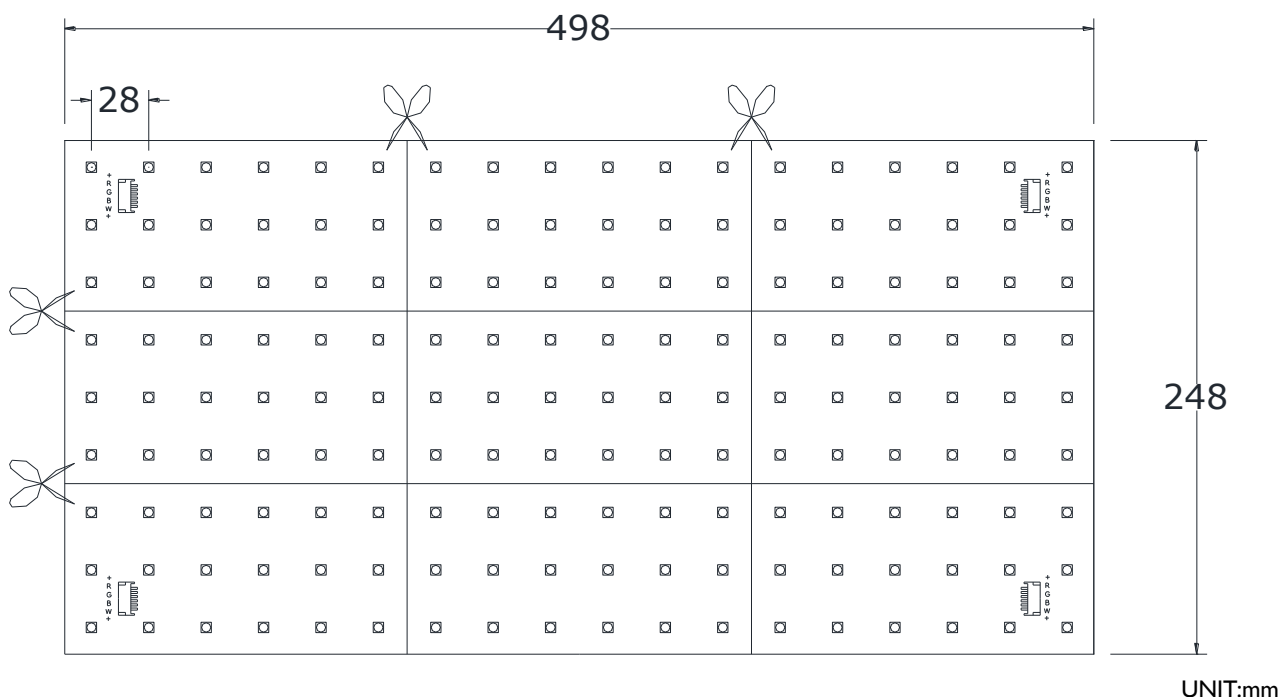

Wiring diagram 1

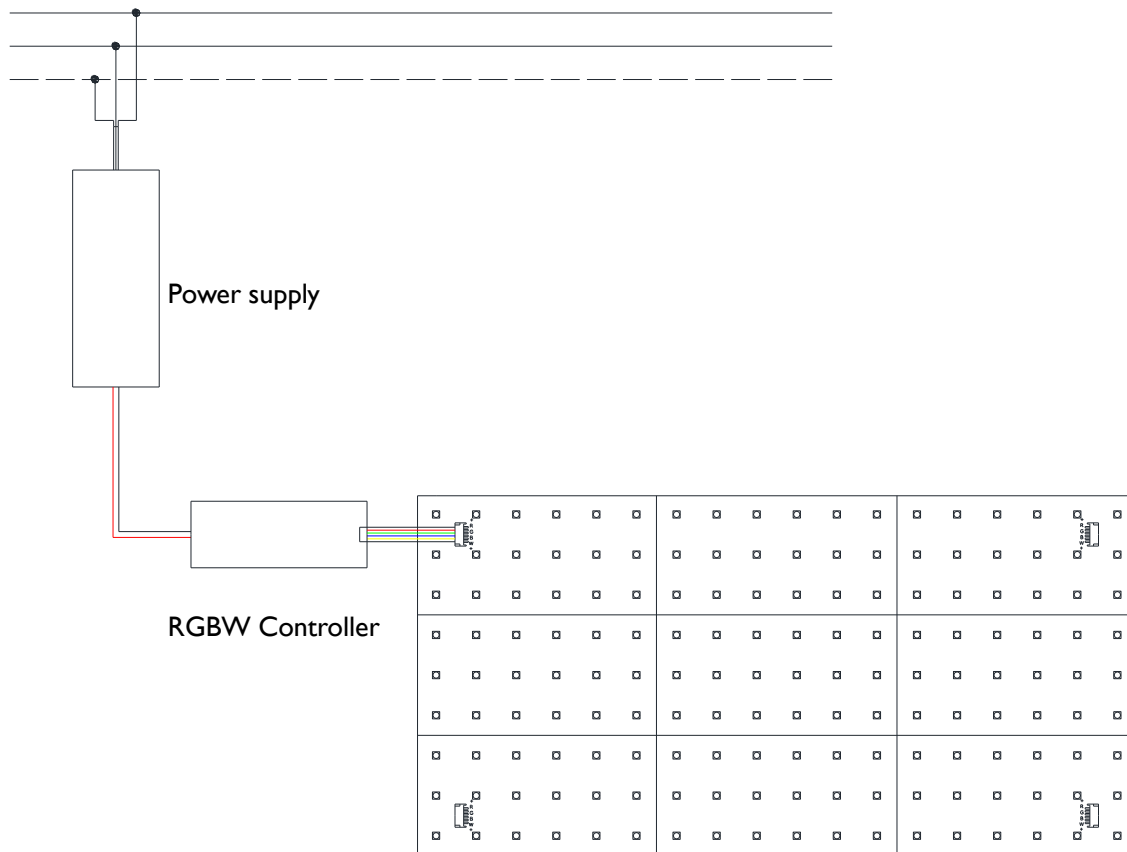

Single connection, constant voltage power supply is 120% LED module power

Wiring diagram 2

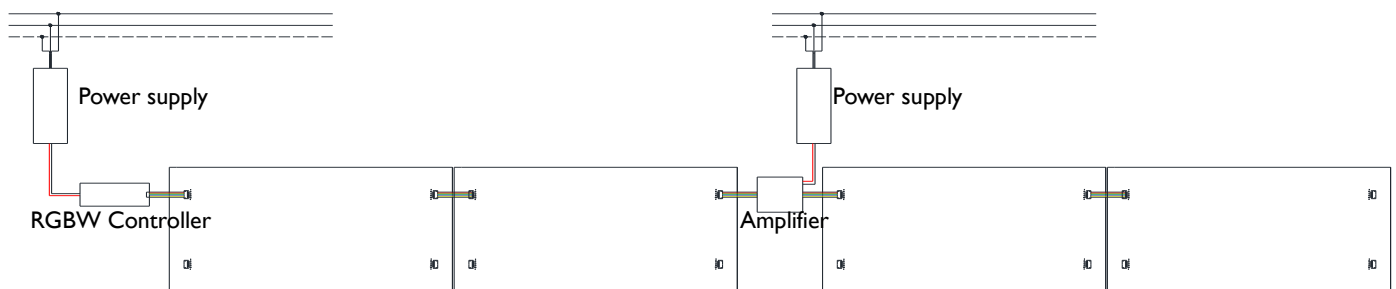

If you need a larger size stitching, increase the LED power supply and LED Amplifier

Safety Information CAUTION: This product is installed by a professional engineering staff.

1. The LED module itself and all its components may not be mechanically stressed.
2. Assembly must not damage or destroy conducting paths on the circuit board.
3. Installation of LED lamp (with power supplies) needs to be made with regard to all applicable electrical and safety standards. Only qualified personnel should be allowed to perform installations.
4. Correct electrical polarity needs to be observed. Wrong polarity may destroy the LED module
5. Parallel connection is highly recommended as safe electrical operation mode.
6. Serial connection is not recommended. Unbalanced voltage drop can cause hazardous overload and damage the LED panel.
7. Please ensure that the power supply of adapters power to operate the total load.
8. When mounting on metallic or otherwise conductive surfaces, there needs to be an electrical isolation points between strip and the mounting surface.
9. Pay attention to standard ESD precautions when installing the LED panel.
10. Damaged by corrosion will not be honored as a materials defect claim. It is the user's responsibility to provide suitable protection against corrosive agents such as moisture and condensation and other harmful elements.